

PSxxTSL Series

Straddle leg Electric Pedestrian Stacker with capacities of 1200/1600/1800kg

INTRODUCTION

- Safe, Compact and Ergonomic Long Tiller Design
- Precise Lifting and Lowering with Fully Proportional Hydraulic System
- Powerful, Maintenance Free German AC Power Train
- Core Components from Top Quality Brands
- 3 Wheel Structure for Stability

ADVANTAGES:

- The PSxxL series is tailored to most pedestrian controlled stacking operations with capacities from 2600 lbs to 4000lbs.
- Ergonomic tiller allows for efficient and safe operation.
- Proportional lifting allows for efficient and safe lifting of any product at any lift speed.
- By using high quality, state of the art components, this stacker will out perform and last longer than comparable stackers on the market today.



Straddle leg

Adjustable straddle leg design, suitable for diverse pallet sizes and more stability.



Easy Assembly

Multi position straddle allows for easy assembly, multiple pallet widths and excellent stability.

CAN-BUS

CANBUS technology

CANBUS technology allows for fewer wires and increased dependability. CANBUS technology slows for easier adjustments and troubleshooting reducing downtime. New digital display outperforms analog.



ZAPI controller

ZAPI controller and Battery Indicator with hour meter as well as fault code display for easy maintenance.



For every application the right battery capacity

With the PSxxTSL series for every truck the right battery: PS12TSL 24 volt 180 Ah battery; PS16/18TSL 24 volt 270Ah battery standard.



Built in USB connector

USB connector for charging of additional devices during warehouse operations.



Maintenance friendly

The truck design and component placement allow for easy service and maintenance. Two screws are used to hold cover in place allowing fast and easy access to all components. Drive wheel and caster can be removed and replaced without use of additional lifting devices.



Electronic proportional lifting and lowering

The electronically controlled proportional lifting system ensures accurate positioning and stacking operations at every lifting height. Proportional lifting increases productivity especially at higher lift heights.

Long tiller design for ergonomics and safety

Through the long tiller design the operator can always keep a safe distance to the truck during proceeding the work very ergonomically.

The long tiller allows the operator to keep a safe distance while providing precision operations.

Reduced force to the operator allows for easy and ergonomic control of the operation of the truck.

Handle operating heights are varied allowing for comfortable and efficient use of multiple operators.

Mast table PS12TSL/PS16TSL/PS18TSL

Designation	Lowered mast height h1(mm)	Free lift height h2(mm)	Lift height h3(mm)	Lift+fork height h3+h13(mm)	Extended mast height h4(mm)
PS12TSL					
Two-stage mast	1958	/	2830	3380	2880
	2108	/	3130	3680	3180
	2308	/	3530	4080	3580
Two-stage mast FFL (Full-Free-Lift)	1958	1410	2830	3380	2880
	2108	1560	3130	3680	3180
	2308	1760	3530	4080	3580
PS16TSL					
Two stage mast	1958	/	2830	3380	2880
	2108	/	3130	3680	3180
	2308	/	3530	4080	3580
Two stage mast FFL (Full-Free-Lift)	1958	1410	2830	3380	2880
	2108	1560	3130	3680	3180
	2308	1760	3530	4080	3580
Three stage mast	2008	/	4230	4780	4280
	2108	/	4530	5080	4580
Three stage mast FFL (Full-Free-Lift)	1908	1320	3930	4480	3980
	2008	1420	4230	4780	4280
	2108	1520	4530	5080	4580
	2343	1756	5230	5780	5280
PS18TSL					
Two stage mast	2078	/	2830	3500	2880
	2228	/	3130	3800	3180
	2428	/	3530	4200	3580
Two stage mast FFL (Full-Free-Lift)	1978	1310	2630	3300	2680
	2078	1410	2830	3500	2880
	2228	1560	3130	3800	3180
	2428	1760	3530	4200	3580
Three stage mast	2128	/	4230	4900	4280
	2228	/	4530	5200	4580
Three stage mast FFL (Full-Free-Lift)	1978	1310	3930	4600	3980
	2128	1420	4230	4900	4280
	2228	1520	4530	5200	4580

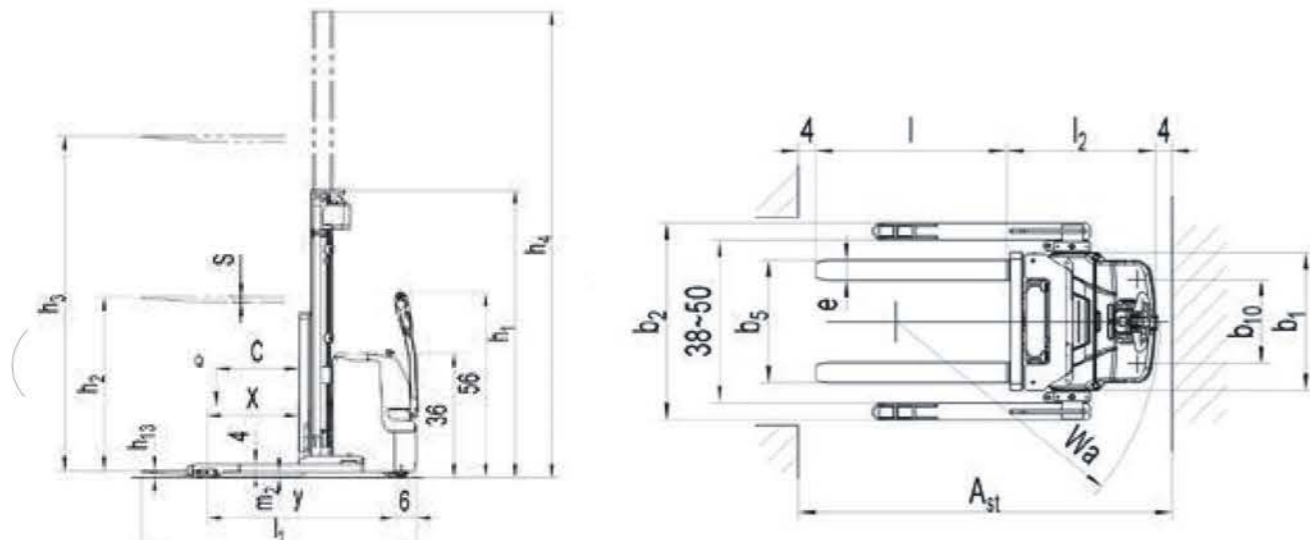

Type sheet for industrial truck acc. to VDI 2198 1KG=2.2LB 1INCH=25.4MM

Identification		PS12TSL(3600)	PS16TSL(4600)	PS18TSL(4600)
1.2	Manufacturer's type designation			
1.3	Drive		Battery	
1.4	Operator type		Pedestrian	
1.5	Load Capacity / rated load	Q (t)	1.2	1.6
1.6	Load centre distance	c (mm)	600	600 ¹⁾
1.8	Load distance ,centre of drive axle to fork	x (mm)	647	647 ²⁾
1.9	Wheelbase	y (mm)	1331	1378
Weights				
2.1	Service weight	kg	1190	1480
2.2	Axle loading, laden front/rear	kg	774/1598	827/2253
2.3	Axle loading, unladen front/rear	kg	796/394	864/616
Wheels, Chassis				
3.1	Tires		Polyurethane (PU)	
3.2	Tire size,front	Øx w (mm)	Φ230×70	
3.3	Tire size,rear	Øx w (mm)	Φ84×70	
3.4	Additional wheels(dimensions)	Øx w (mm)	Φ100x40	
3.5	Wheels,number front/rear(x=driven wheels)		1x+2/4	
3.6	Tread, front	b10 (mm)	500	
Basic Dimensions				
4.2	Lowered mast height	h1(mm)	2308	2108
4.3	Free Lift height	h2(mm)	1760	1520
4.4	Lift	h3(mm)	3560	4530
4.5	Extended maximal height	h4(mm)	4088	5088
4.9	Height of tiller in drive position min./ max.	h14 (mm)	890/1420	
4.15	Height, lowered	h13 (mm)	50	
4.19	Overall length	l1 (mm)	1990	2075
4.20	Length to face of forks	l2 (mm)	840	925
4.21	Overall width	b1 (mm)	816/1170-1470	
4.22	Fork dimensions	s/e/l (mm)	35x100x1150	40x120x115
4.25	Width across forks	b5 (mm)	235-710	255-730
4.32	Ground clearance, centre of wheelbase	m2 (mm)	40	
4.33	Aisle width for pallets1000X1200 crossways	Ast (mm)	2396	2437
4.34	Aisle width for pallets800X1200 lengthways	Ast (mm)	2382	2418
4.35	Turning radius	Wa (mm)	1500	1550
Performance Data				
5.1	Travel speed, laden/ unladen	km/h	5.4/6.0	5.4/6.0
5.2	Lift speed, laden/ unladen	m/s	0.09/0.14	0.13/0.18
5.3	Lowering speed, laden/ unladen	m/s	0.25/0.2	0.20/0.14
5.8	Max. gradeability, laden/ unladen	%	6/12	6/12
5.10	Service brake		Electromagnetic	
E-Motor				
6.1	Drive motor rating S2 60min	kW	1.3	1.4
6.2	Lift motor rating at S3 10%	kW	1.5	3.2
6.3	Battery acc. to DIN 43531/ 35/ 36 A, B, C, no		2PZB	3VBS
6.4	Battery voltage, nominal capacity K5	V / Ah	24/180	24/270
6.5	Battery weight	kg	175	230
6.6	Energy consumption acc. to VDI cycle	kWh/h	0.95	1.59
Other Details				
8.1	Type of drive control		AC- speed control	
8.4	Sound level at driver's ear acc. to EN 12053	dB(A)	<70	